

Top View of Assembly

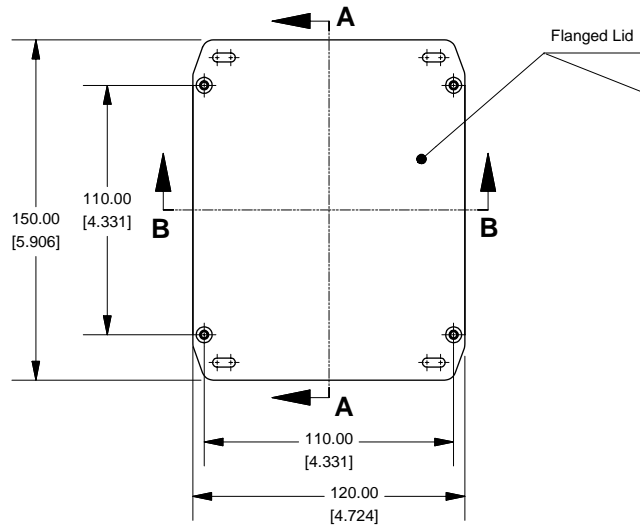

SECTION A-A  
Side View of Assembly

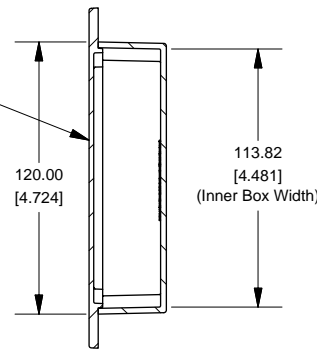

### Series 1590QFL (Flanged Lid)

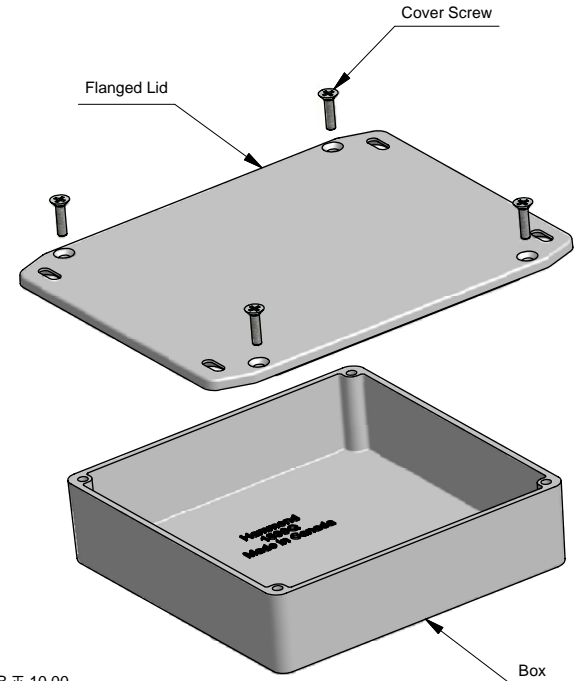

SECTION B-B  
End View of Assembly

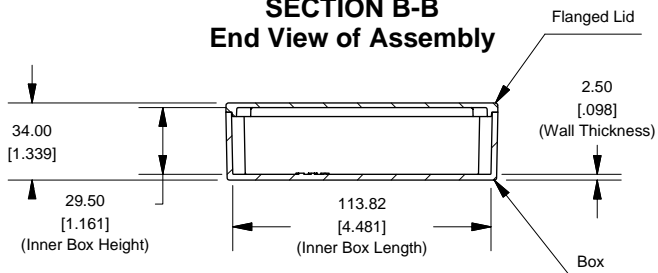

Top View Looking Inside Box

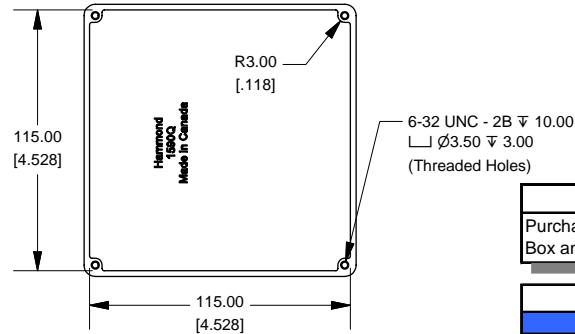

**NOTE**

Purchased assembly includes box, lid and 4 cover screws.  
Box and lid are made from Diecast Aluminum Alloy (alloy type 360.1).

**PART NUMBERS**

1590QFL Enclosure	
Unfinished	1590QFL
Black Textured Powder Paint	1590QFLBK
<b>1590QFL Liquid Resistant Enclosure (Silicon Factory Installed Gasket)</b>	
Unfinished	1590WQFL
Black Textured Powder Paint	1590WQFLBK
ACCESSORIES	
Unfinished	
Cover Screws (Pkg 100) [6-32 x 1/2" Nickel Plated Screws]	1590MS100
Black Textured Powder Paint	
Cover Screws (Pkg 50) [6-32 x 1/2" Stainless Steel Black Screws]	1590MS50BK

Flanged Lid

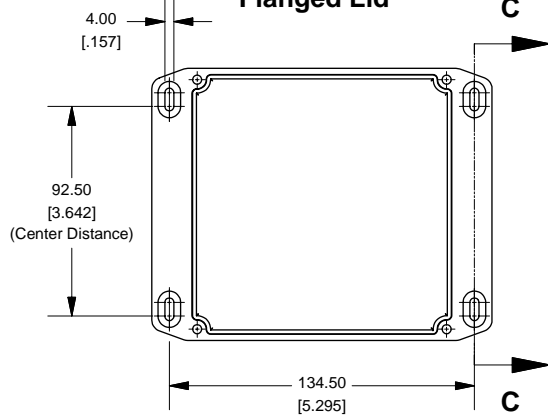

SECTION C-C  
Side View of Slot

